

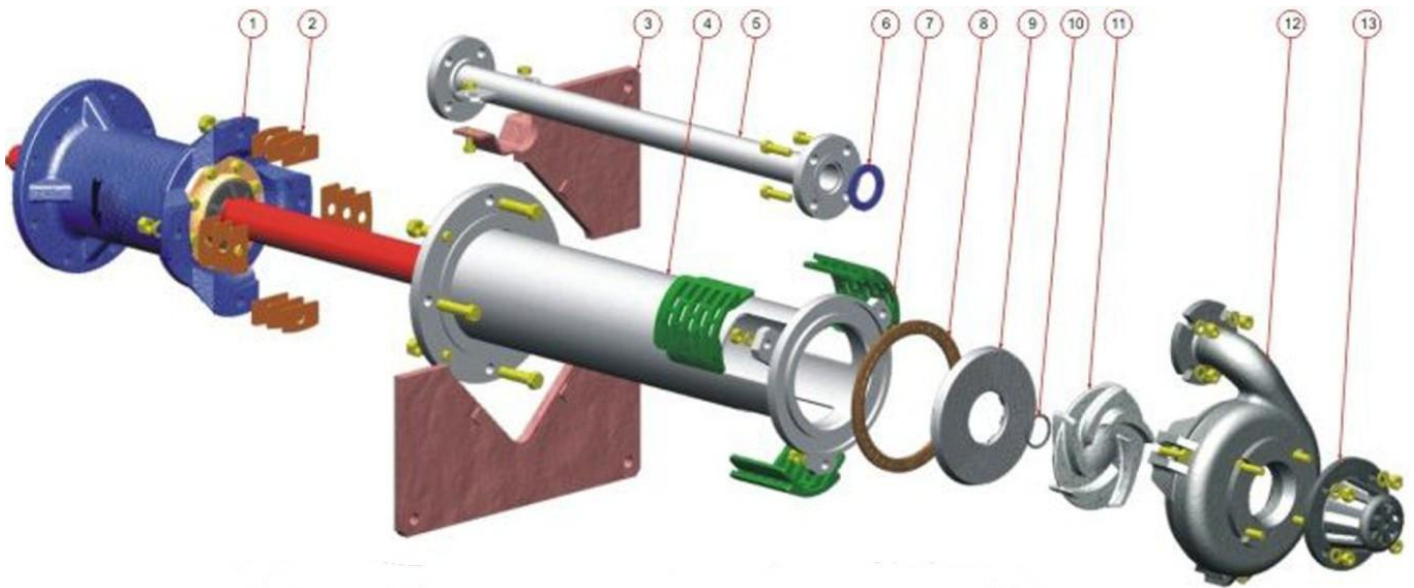

With unique cantilevered design, EVM series sump pumps doesn't need any seal and seal water. This series of pumps are preferred by many customers with special installation requirements and widely applied in pool. Its wear-resistant metal liner could handle abrasive slurries with rough particles and high concentration.



- Doesn't need any seal and the seal water;
- Work normally even if the suction volume is not enough;
- Single casing structure with the advantages of light weight, small volume, easy installation;
- Anti-abrasive wet parts made of high-chrome alloys;
- Transmission shaft and suction pipe could be chosen according to liquid surface of the slurry pool;
- Slurry pump agitator could be installed to improve transfer efficiency;
- Able to run smoothly under various speeds.

## ❖ Structure

### Series EVM structural drawing:

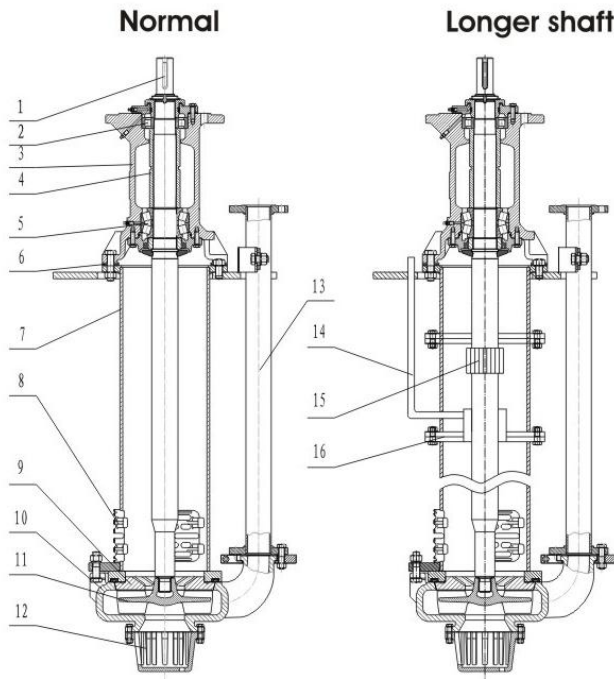

- |                     |                             |
|---------------------|-----------------------------|
| 1. Shaft            | 9. Back liner               |
| 2. Bearing D        | 10. Casing                  |
| 3. Bearing house    | 11. Impeller                |
| 4. Bearing retainer | 12. Lower strainer          |
| 5. Bearing          | 13. Discharge pipe          |
| 6. Adjusting shim   | 14. Water seal pipe         |
| 7. Column           | 15. Coupling                |
| 8. Strainer         | 16. Middle support assembly |

Note: this is the basic structural drawing. There is a little difference up to the varied discharge sizes.



### Shaft

According to the depth of pools' liquid level, shaft length and suction pipe of different sizes are available.

### Material

The wear parts material for EVM series pump is high-chrome alloy. This kind of material is wear resistant and has excellent performance under erosive conditions.

- KmTBCr27: hard carbides within its microstructure provides strong wear resistance
- KmTBCr28: its hardness is 430 in Brinell and suitable for corrosive applications where pH is below 4.
- KmTBCr35: its hardness is 450 in Brinell and has much improved corrosion resistance.

## ❖ Performance Chart

Model	Allowable Max.Power P(Kw)	Clear Water Performance					Impeller
		Capacity Q		Head H(m)	Speed n(r/min)	Top Efficiency η%	Impeller Diameter D(mm)
		m <sup>3</sup> /h	l/s				
EVM-40P	15	17-43.2	4.7-12	4-28.5	1000-2200	40	188
EVM-65Q	30	18-114	5-32	5-31.5	750-1500	60	280
EVM-100R	75	54-289	15-80	5-36	500-1200	62	370
EVM-150S	110	108-479	30-133	8.5-40	500-1000	52	450
EVM-200S	110	189-891	52.5-247.5	6.5-37	400-850	64	520
EVM-250T	200	360-1150	100-320	7-33	400-750	60	575
EVM-300T	200	540-1548	150-430	5.5-26	350-700	60	580

## ❖ Application

Series EVM slurry pumps are widely used in the mining, coal washing, power plant, metallurgy, petrochemical, building material, dredging, and other industrial departments, etc.

### Typical Application:

- Iron Ore Dressing Plant
- Copper Concentration Plant
- Gold Mine Concentration Plant
- Molybdenum Concentration Plant
- Potash Fertilizer Plant
- Other Mineral Processing Plants
- Alumina Industry
- Coal Washery
- Power Plant
- Sand Excavation
- Building Material Industry
- Chemical Industry
- Other industries

*EVM-40P Copper Mineral Processing in Africa*



*EVM-150S in Chinese Gold Processing Plant*

**Headquarter:**

Add: No.368, Xinshi North Road, Shijiazhuang, Hebei, China 050091.

**Beijing Branch:**

Add: No.78, East 4th Ring Middle Road, Beijing, China 100124.

Tel: +86-10-81107022

Fax: +86-10-81107016

For inquiries, please send your emails to [sales@excellencepump.com](mailto:sales@excellencepump.com)

For customer service, please send your emails to [service@excellencepump.com](mailto:service@excellencepump.com)