



EVF series froth pumps are the latest generation of froth pump based on advanced technology at home and abroad. It is ideal product for the transporting of slurries with lots of froth, especially the slurries in the flotation process.

- EVF series is suitable for transporting slurry with froth, especially for flotation processing.
- EVF series can eliminate the froth in the running slurry and work normally even if the feeding slurry is not enough.
- The feeding suction in the tangent line can accelerate slurry transporting and eliminate part of the froth.
- The belt and pulley are easy to be altered in order to change the speed according to the working condition.
- Interchangeable wet parts are made of special alloy, rubber or other wear-resistant materials according to slurry properties.





## ❖ Structure



- |                 |                       |                     |
|-----------------|-----------------------|---------------------|
| 1. Cover plate  | 4. Spiral front liner | 7. Bearing assembly |
| 2. Volute liner | 5. Feeding box        | 8. Feeding inlet    |
| 3. Frame plate  | 6. Overflow           | 9. Impeller         |

Note: this is the basic structural drawing. There is a little difference up to the varied discharge sizes.

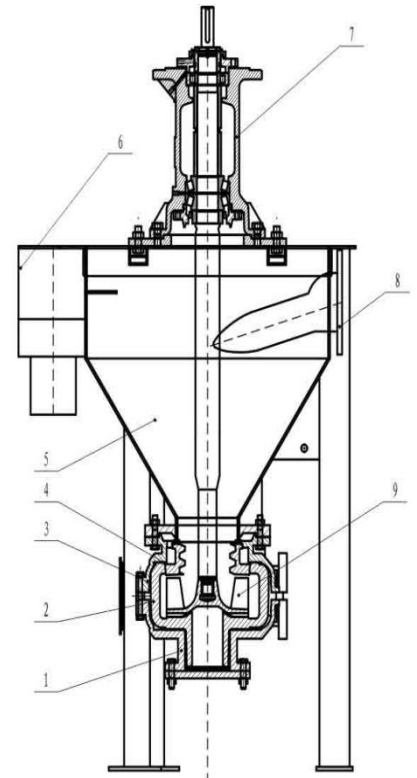

### Box

The box is made of steel, stainless steel or rubber lined steel.

- The feeding suction in the tangent line can accelerate slurry transporting and eliminate part of the froth.
- The overflow box could deliver the surplus slurry back to the pool.

### Impeller

The impeller of EVF series is open with 5 vanes, which can avoid blockage.

### Material

The wet parts material for standard EHM series pump is high-chrome alloy. This kind of material is wear resistant and has excellent performance under erosive conditions.

- KmTBCr27: hard carbides within its microstructure provides strong wear resistance
- KmTBCr28: its hardness is 430 in Brinell and suitable for corrosive applications where pH is below 4.
- KmTBCr35: its hardness is 450 in Brinell and has much improved corrosion resistance.

## ❖ Performance Chart

	Allowable Max. Power P(Kw)	Clear Water Performance						Impeller
		Capacity Q		Head H(m)	Speed n(r/min)	Top Efficiency η%	NPSH(m)	Impeller Diameter D(mm)
		m <sup>3</sup> /h	l/s					
EVF-2Q	15	7.2-33	2-9.2	5-30	800-1800	45	229	EVF-2Q
EVF-3Q	20	10-104	2.7-29	10-28	800-1400	55	268	EVF-3Q
EVF-4R	40	15-130	4.2-36	6-28	500-1000	55	397	EVF-4R
EVF-6S	75	55-330	15.3-92	6-25	350-680	55	560	EVF-6S

## ❖ Application

Series EHM slurry pumps are widely used in the mining, coal washing, power plant, metallurgy, petrochemical, building material, dredging, and other industrial departments, etc.

### Typical Application:

- Iron Ore Dressing Plant
- Copper Concentration Plant
- Gold Mine Concentration Plant
- Molybdenum Concentration Plant
- Potash Fertilizer Plant
- Other Mineral Processing Plants
- Other industries



**Headquarter:**

Add: No.368, Xinshi North Road, Shijiazhuang, Hebei, China 050091.

**Beijing Branch:**

Add: No.78, East 4th Ring Middle Road, Beijing, China 100124.

Tel: +86-10-81107022

Fax: +86-10-81107016

For inquiries, please send your emails to [sales@excellencepump.com](mailto:sales@excellencepump.com)

For customer service, please send your emails to [service@excellencepump.com](mailto:service@excellencepump.com)