

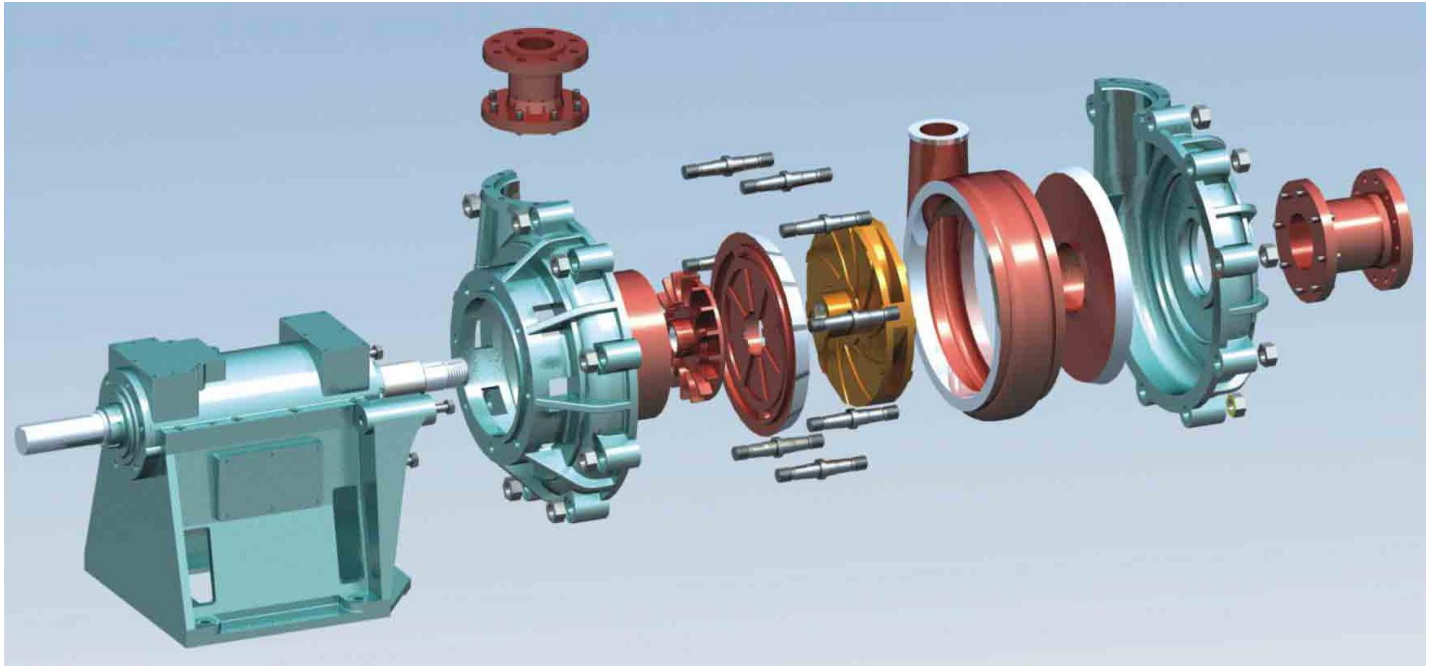

EGM series slurry pumps are heavy duty slurry pumps and have outstanding performance in high head applications. This series are suitable for handling low corrosive slurries of various concentrations.



- Superb performance in high head application
- Cylindrical structure of bearing assembly: convenient to adjust the space between impeller and front liner and can be removed completely;
- Interchangeable anti-abrasive wet parts made of high-chrome alloys;
- The discharge branch can be oriented to any eight positions at the interval of 45 degrees;
- It can be installed in multistage series to meet the delivery for long distance;
- Various drive types: DC(direct connection), V-belt drive, gear box reducer, hydraulic couplings, VFD, SCR control, etc;
- The shaft seal uses the packing seal, expeller seal and mechanical seal;

❖ Structure

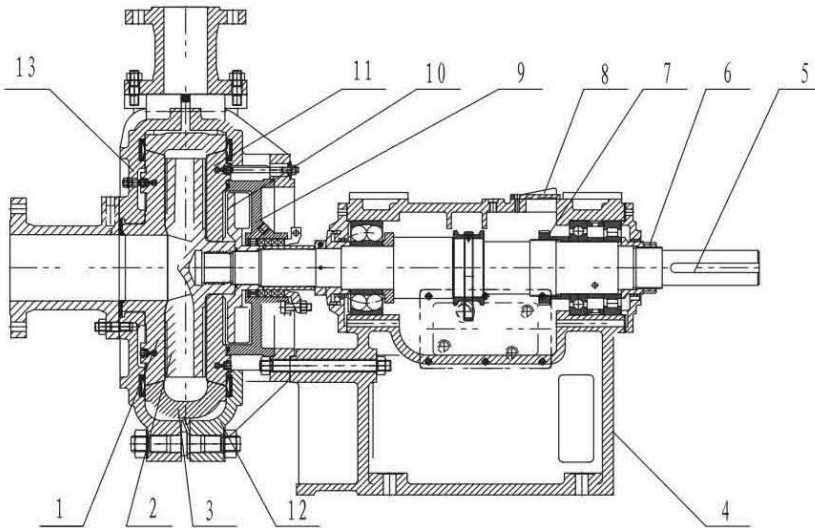

1. Throatbush
2. Impeller
3. Volute liner
4. Support
5. Shaft
6. Adjusting screw II
7. Adjusting screw I
8. Adjusting hole cover
9. Expeller ring
10. Expeller
11. Frame plate liner insert
12. Frame plate
13. Cover plate

Note: this is the basic structural drawing. There is a little difference up to the varied discharge sizes.



Shaft Seal

There are three standard shaft seal methods:

- Packing seal: it is the lowest in cost.
- Expeller seal with packing seal: it is most commonly used.
- Mechanical seal: it has best seal effect, but high in cost and has strict requirement of flush water.

Bearing Assembly

Convenient to adjust the space between impeller and front liner and can be removed completely;

- Lubricated by grease;
- Easy maintenance.

Material

The wet parts material for standard EGM series pump is high-chrome alloy. This kind of material is wear resistant and has excellent performance under erosive conditions.

- KmTBCr27: hard carbides within its microstructure provides strong wear resistance
- KmTBCr28: its hardness is 430 in Brinell and suitable for corrosive applications where pH is below 4.
- KmTBCr35: its hardness is 450 in Brinell and has much improved corrosion resistance.

❖ Performance Chart

	Allowable Max. Power P(Kw)	Clear Water Performance						Impeller
		Capacity Q		Head H(m)	Speed n(r/min)	Top Efficiency η%	NPSH(m)	Impeller Diameter D(mm)
		m ³ /h	l/s					
EGM-1C	30	16.2-34.2	4.9-9.5	25-92	1400-2200	20	2-2.5	330
EGM-2D	60	68.4-136.8	19-38	25-87	850-1400	47	3-7.5	457
EGM-3E	120	126-252	35-70	12-97	600-1400	50	2-5	508
EGM-4S	560	324-720	90-200	30-118	600-1000	64	3-8	711
EGM-6S	560	468-1008	130-280	20-94	500-1000	65	4-12	711

❖ Application

Series EGM slurry pumps are widely used in the mining, coal washing, power plant, metallurgy, petrochemical, building material, dredging, and other industrial departments, etc.

Typical Application:

- Iron Ore Dressing Plant
- Copper Concentration Plant
- Gold Mine Concentration Plant
- Molybdenum Concentration Plant
- Potash Fertilizer Plant
- Other Mineral Processing Plants
- Alumina Industry
- Coal Washery
- Power Plant
- Sand Excavation
- Building Material Industry
- Chemical Industry
- Other industries



EGM-6S Coal Washery in Australia



Headquarter:

Add: No.368, Xinshi North Road, Shijiazhuang, Hebei, China 050091.

Beijing Branch:

Add: No.78, East 4th Ring Middle Road, Beijing, China 100124.

Tel: +86-10-81107022

Fax: +86-10-81107016

For inquiries, please send your emails to sales@excellencepump.com

For customer service, please send your emails to service@excellencepump.com